

## 50 HP Trailer Mounted Hydraulic Power Unit

### Fast Facts

*DOT Approved for Highway Towing*

Horsepower:  
50 HP

Operating Pressure:  
2500 to 3500 PSI

Hydraulic Flow  
4 to 21 GPM

Hydraulic Tank  
80 Gal

Diesel Tank  
56 Gal

Weight:  
3500 LBS

Dimensions:  
**132" x 70" x 74"**

Hydraulic Oil:  
32 or 46 AW, BIO, NS



### FEATURES

#### Engine

- Isuzu Diesel Engine with 5 Year / 5000 hr Warranty
- EPA Rated Engine with rubber engine shock points
- LOFA or Murphy engine monitoring system
- Engine safety shutdown package
- Double fuel and hydraulic filtration
- Optional Air inlet shutdown valve
- Electric start with battery & weather safe battery box

#### Hydraulics

- Single or twin circuit variable flow hydraulic controls
- High capacity hydraulic cooling system
- Hydraulic oil filter with spin on cartridge
- Oil spill and fuel spill containment trailer
- 5000 PSI hydraulic gauges
- Screw together 3/4" or 1" supply and return fittings
- Hydraulic oil level & temperature indicators
- Low level hydraulic fluid shutdown

#### Available Options

- Fully custom hydraulic circuits, pressures, and flow
- Air or electric start; mechanical or electric shutdown
- Integrated hydraulic hose reels
- Optional hydraulic pressure washers

#### Safety

- Safety transport center point eye pad
- DOT approved trailer - fully wired for highway towing
- System hydraulic relief valve
- Front & rear safety transport binder rings
- Easy to read safety and operation labeling
- Flame arrestor exhaust with heat shield
- 10 Ply trailer tires

#### Other Features

- Powder coated frame & box tube lifting design
- Fully adjustable Pintle or Bulldog hitch & trailer jack
- Torsion flex removable trailer axles - no leaf springs
- Top tank desiccant breather
- 10" Oversized tank clean out ports
- 60 or 100 GPM hydraulic cooler options
- Removable fuel and hydraulic tanks
- Low point drain plugs

# ▶ Fast Flow - Hydraulic Power Units

## 50 HP Isuzu 4LE1

- Naturally Aspirated Diesel
- 4 Cylinder Liquid Cooled
- (50HP / 37 KW) Output
- 2.2 (L) Displacement
- 2600 Max RPM
- EPA Tier 4i Compliant

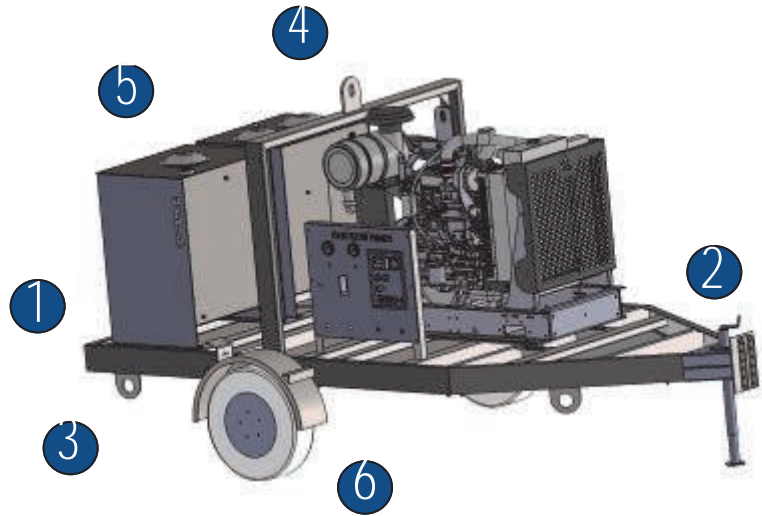

## Fast Flow Standard Features

|                      |                           |                         |
|----------------------|---------------------------|-------------------------|
| 1. Removable Tanks   | 3. Transport Binder Rings | 5. Tank Clean Outs      |
| 2. Spill Containment | 4. H.D. Center Lift Point | 6. Trailer 10 Ply Tires |

## Specialty features are standard

with **Fast Flow's** trailer-mounted hydraulic power units. Fluid spill containment, removable fuel and hydraulic tanks, and oversized tank clean outs, and DOT certification for highway towing come standard. Choose from an adjustable height bulldog or pintle hitch. Fast Flow trailer hydraulic power units are designed to be maintenance friendly resulting in less costly servicing and improved life span.

### 4LE1 Industrial Performance Curves:

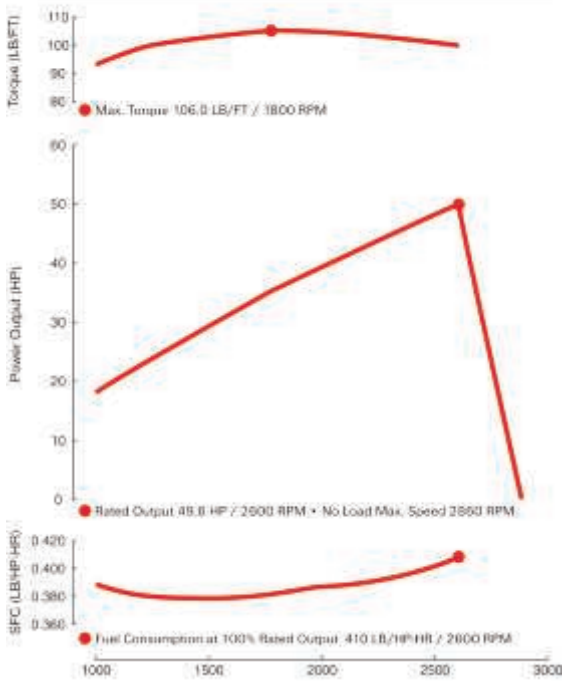

## Pump and Power Unit Selector

|                     | 30 HP Electric | 38 HP Diesel | 30 HP Electric | 50 HP Diesel | 75 HP Electric | 99 HP Diesel | 125 HP Diesel | 154 HP Diesel |
|---------------------|----------------|--------------|----------------|--------------|----------------|--------------|---------------|---------------|
| 2" Pumps            | Green          | Green        | Green          | Green        | Green          | Green        | Green         | Green         |
| 3" Pumps            | Green          | Green        | Green          | Green        | Green          | Green        | Green         | Green         |
| 3" Twin Motor Pumps | Red            | Red          | Red            | Green        | Green          | Green        | Green         | Green         |
| 4" Pumps            | Red            | Red          | Red            | Green        | Green          | Green        | Green         | Green         |
| 4" Twin Motor Pumps | Red            | Red          | Red            | Green        | Green          | Green        | Green         | Green         |
| 6" Pumps            | Red            | Red          | Red            | Red          | Green          | Green        | Green         | Green         |
| 6" Twin Motor Pumps | Red            | Red          | Red            | Red          | Red            | Green        | Green         | Green         |

Fast Flow, LLC and Fast Flow Pumps manufactured pumps are protected under: 35 U.S.C., 37 C.F.R. and 18 U.S.C. Fast Flow, LLC and Fast Flow manufactured pumps are covered by one or more of the following patents: United States Patent Number (s): 6,942,448; 7,442,003; 8,152,443; Other Patents Pending approval. Pump curve & capacities represent the pump moving water at an elevation of sea level. Many variables can effect actual pumping performance.